

## AJm (<1 kW) Cast iron self priming pump (<1 kW)

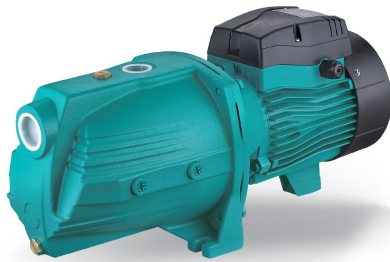
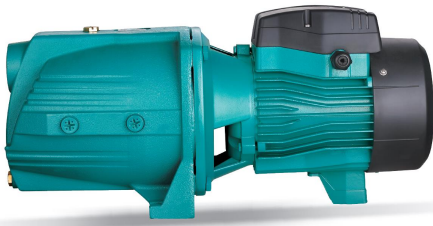

### Application

- Transfer of clear water or other liquids chemically and physically comparable to water
- Suitable for pumping in a well, automatic garden watering, overpressure of water, etc ...

### Pompe

- Special anti-rust treatment (cataphoresis) for the cast iron pump body and the support
- Stainless steel impeller
- AISI 304 stainless steel shaft
- Maximum liquid temperature: +40°C
- Maximum suction height: 8 m

### Moteur

- Integrated thermal protection for single-phase motors
- Insulation class: F
- Protection class: IPX4
- Maximum ambient temperature: +40°C

### Identification codes

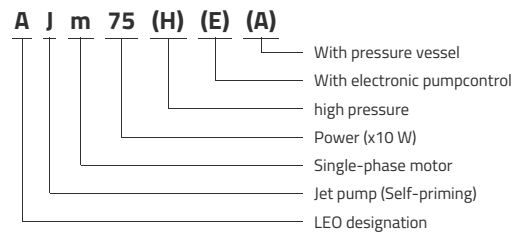

## Technical data

MODEL	kW	Q (m³/h)	0	0.3	0.6	0.9	1.2	1.5	1.8	2.1	2.4	2.8	3	3.3	3.6	3.9
		Q (l/min)	0	5	10	15	20	25	30	35	40	47	50	55	60	65
AJm30	0.3		35	30	26	22.5	20	18	16	14						
AJm45	0.45		41	36	32	28	25	22	20	18						
AJm60	0.6		45	41	37	33.5	31	28.5	26	24	22.5	21				
AJm75	0.75		40	38	36	34.5	33	31.5	30	29	28	27	26	25	24	23
AJm75A	0.75		40	38	36	34.5	33	31.5	30	29	28	27	26	25	24	23
AJm75E	0.75		40	38	36	34.5	33	31.5	30	29	28	27	26	25	24	23
AJm75H	0.75		51	47	43	40	37	34.5	32	30	27.5	25				
AJm90	0.9		48	46	44	42.5	41	39.5	38	36	35	34	33	32	31	30
AJm90A	0.9		48	46	44	42.5	41	39.5	38	36	35	34	33	32	31	30
AJm90E	0.9		48	46	44	42.5	41	39.5	38	36	35	34	33	32	31	30
AJm90H	0.9		62	57	53	49	46	43	40	37	35	33				

## Dimensions

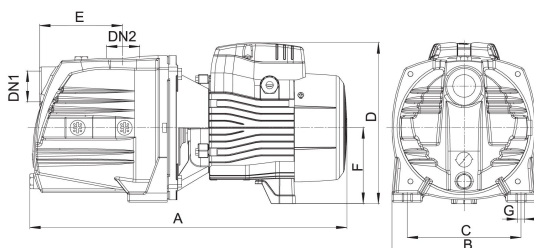

MODEL	DN1	DN2	A	B	C	D	E	F	G
AJm30	1	1	358	160	105	180	89.5	90	10
AJm45	1	1	358	160	105	180	89.5	90	10
AJm60	1	1	418	190	150	212	113	100	10
AJm75	1	1	418	190	150	212	113	100	10
AJm75A									
AJm75E									
AJm75H	1	1	418	190	150	212	113	100	10
AJm90	1	1	418	190	150	212	113	100	10
AJm90A									
AJm90E									
AJm90H	1	1	418	190	150	212	113	100	10

## Hydraulic performance

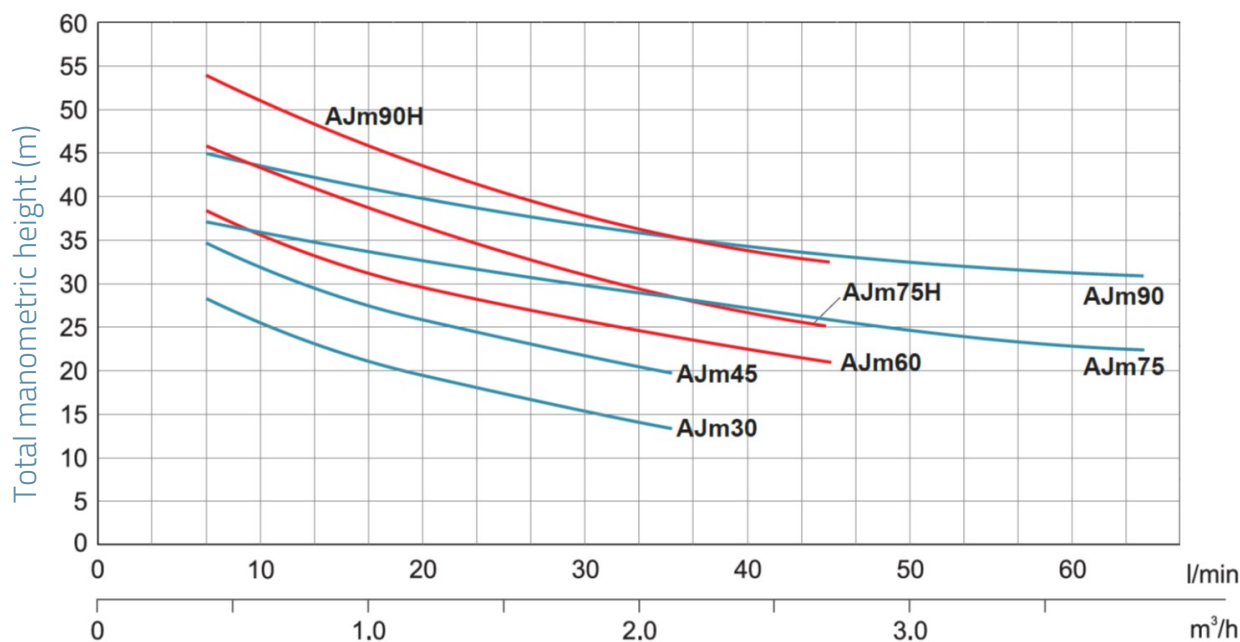

## Exploded view

No.	Type	Materials
1	Pump body	cast iron HT200
2	Venturi tube	noryl (PPO)
3	Diffuser	noryl (PPO)
4	Impeller	AISI 304 stainless steel
5	Mechanical seal	carbon / ceramic
6	O-ring	nitrile rubber (NBR)
7	Pump bottom	AISI 304 stainless steel
8	Lantern	AISI 304 stainless steel
9	Bearing	
10	Rotor	
11	Fan cover	polypropylene
12	Fan	polypropylene
13	Rear cover	cast aluminum ZL102
14	Capacitor	
15	Terminal Box	ABS
16	Terminal board	
17	Stator	

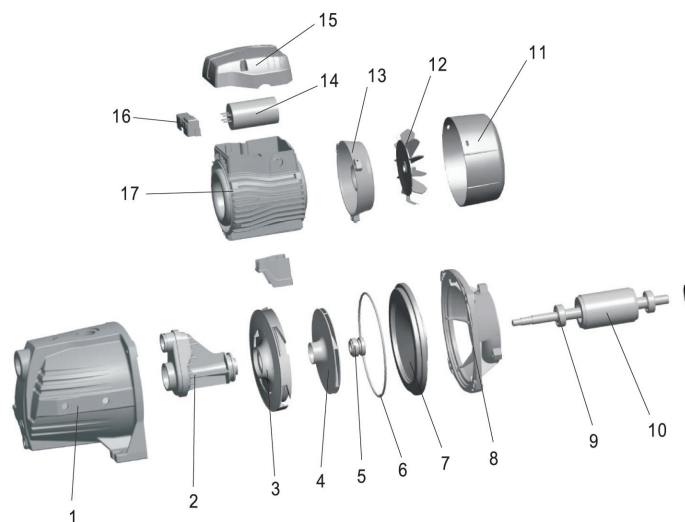

## Packaging

MODEL	Weight (kg)	Length L (mm)	Width W (mm)	Height H (mm)
AJm30	9.2	390	185	215
AJm45	10.15	390	185	215
AJm60	14.35	455	215	245
AJm75	15.5	455	215	245
AJm75A	0	0	0	0
AJm75E	0	0	0	0
AJm75H	15.5	450	215	245
AJm90	16.45	455	215	245
AJm90A	0	0	0	0
AJm90E	0	0	0	0
AJm90H	16.45	450	215	245

